

# AUTOMGEN<sup>7</sup>



www.irai.com

## Automation software

- PLC programming,
- SCADA,
- 3D process simulation,
- electric, pneumatic and hydraulic simulation (with AUTOSIM optional module).

The most powerful AUTOMATION software in the world



# AUTOMGEN for education and industry around the world

Resellers list at:

<http://www.irai.com/reseller.html>

Detailed documentation, price list, and free trial  
version at:

[www.irai.com/index\\_e.html](http://www.irai.com/index_e.html)

Video demonstration with audio comments at:

[www.irai.com/gallery\\_e.htm](http://www.irai.com/gallery_e.htm)

With AUTOMGEN<sup>7</sup>,  
automation program  
designing has never been  
easier.

Users can spend their time  
on their work without  
wasting time with  
complicated handling or  
complex syntax.

Syntax coloration and  
automatic error  
localization make fast  
corrections possible.

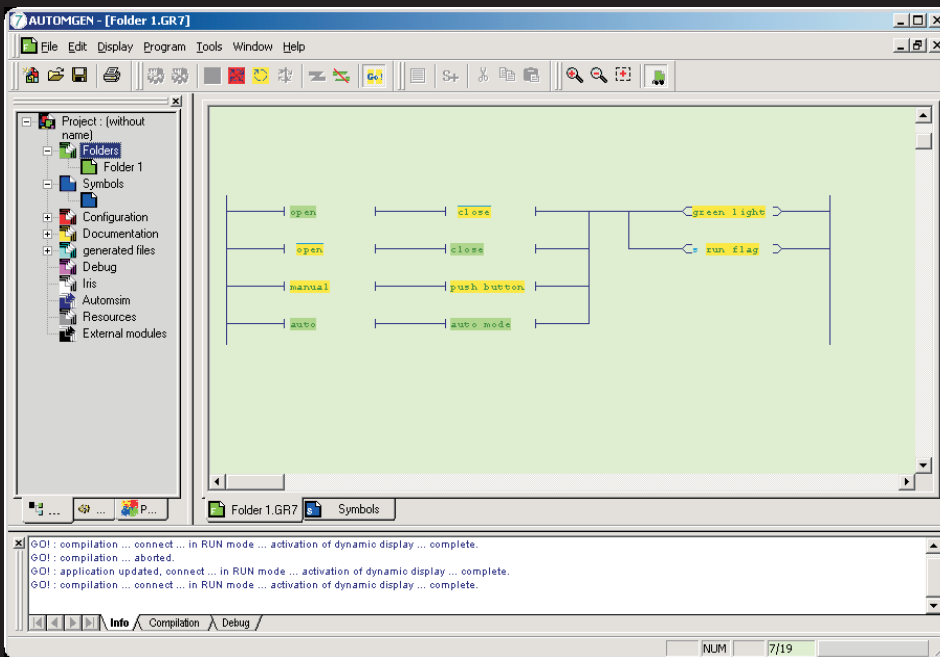
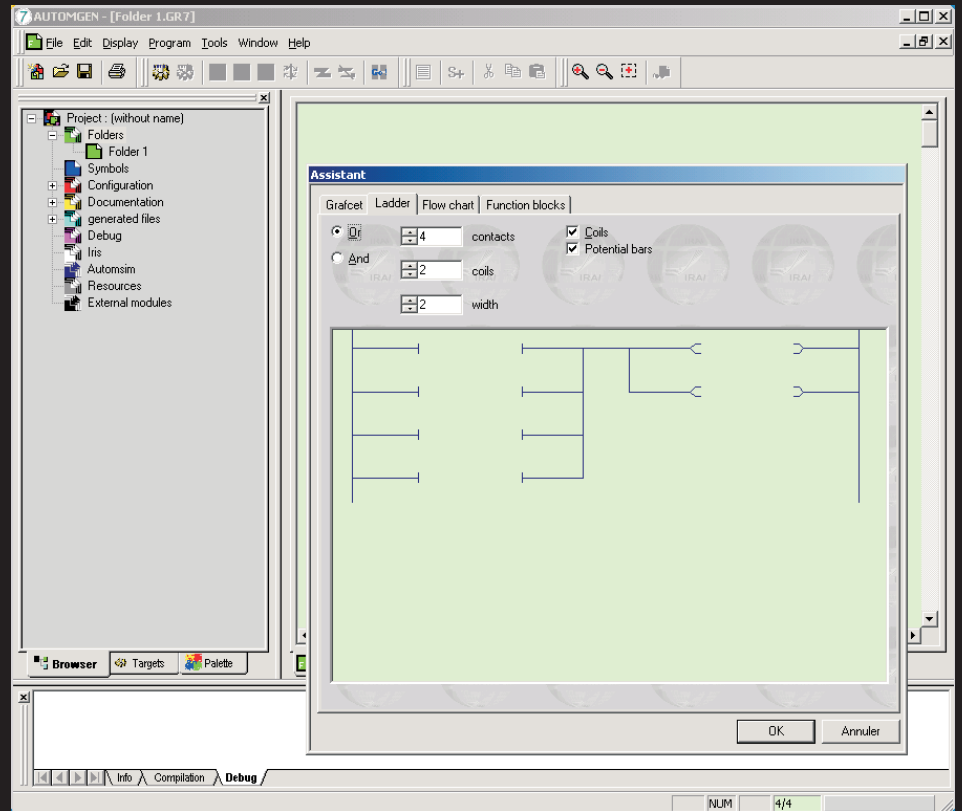

A simple press of the "GO"  
button and the RUN mode  
starts simulation on the PC  
or on a PLC connected to  
the PC.

The dynamic visualisation of  
the evolution of the  
program and the variables  
makes for very easy  
development of the  
application.

Whether AUTOMGEN<sup>7</sup> users are beginners or specialists, they will be able to appreciate the extraordinary productivity of this tool.

The organization of the applications in project form makes it possible to manage them in a rational way, no matter what their sizes.

AUTOMGEN<sup>7</sup> is also used in industry, which is a guarantee of the product's performance.

3D process simulation

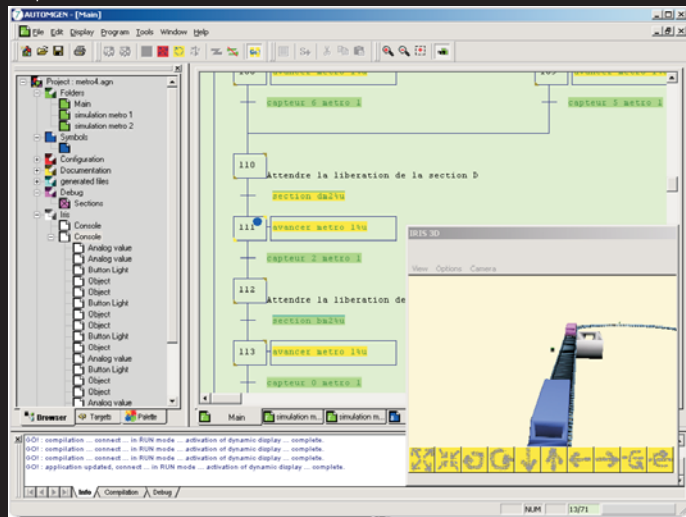

3D process simulation

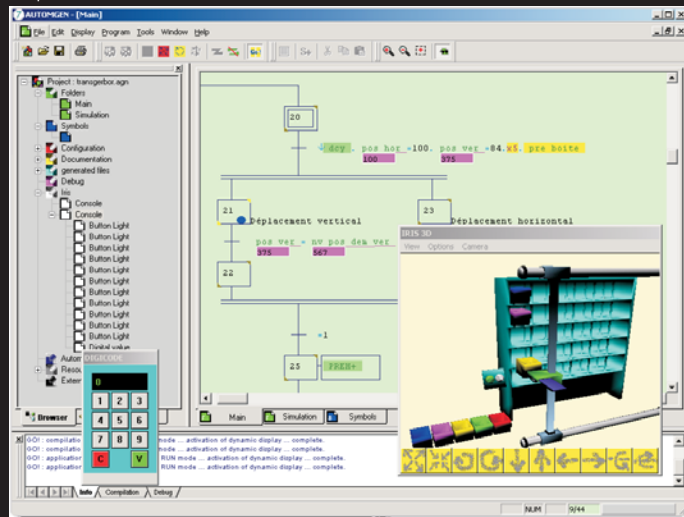

Electric simulation

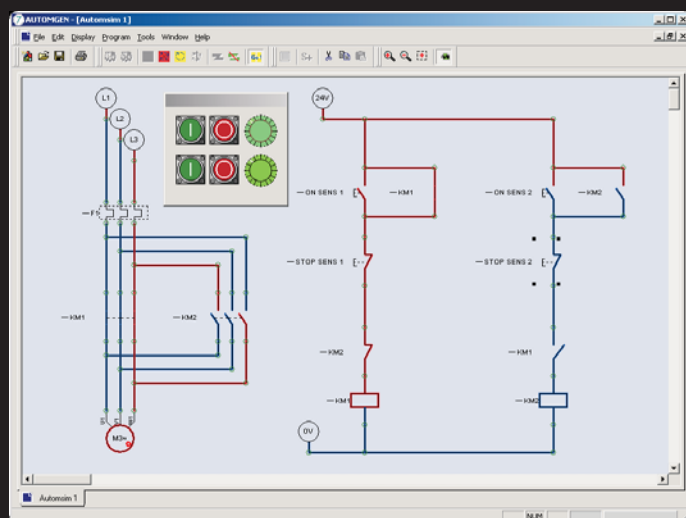

Pneumatic simulation

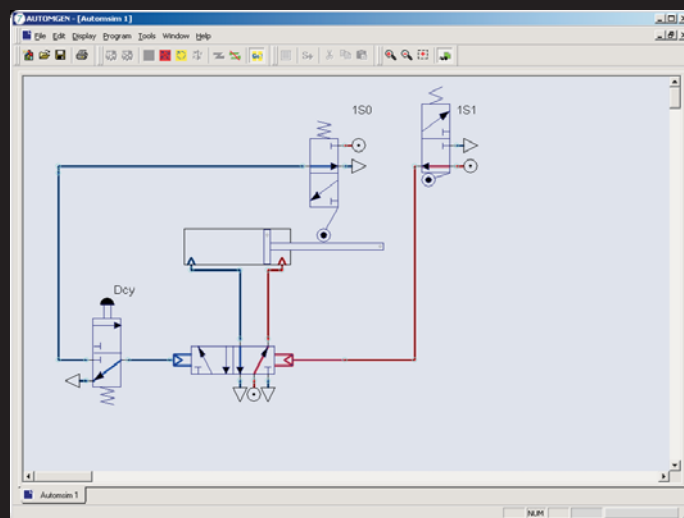

# Technical characteristics

Minimal recommended configuration : Microsoft WINDOWS 2000, XP, 2003, 32 MB RAM, video 1024 x 768 16 bits.

Programming languages : Ladder, Logic, Flow chart, Literal, Function blocks, Grafcet/SFC, CEI 1131-3.

Compatible PLCs : SCHNEIDER (PB, SMC, TSX17-10, 17-20, 47, 07, 37, 57, ZELIO, TWIDO), SIEMENS (S5, S7), ABB (CS31, AC31), KLOCKNER-MOELLER (PS3, PS4, PS414), GE-FANUC (90 Micro, 9030), CEGELEC (C50, C100, 8005, 8035), OMRON (C, CV, CS), MITSUBISHI (FX, Q), FESTO, LANGUAGE C, others (cotact us).

Import of 3D files SOLIDWORKS\*, 3D STUDIO\*, VRML, etc...

Protection : validation code or network license.

# For more information, contact us :

Email : [contact@irai.com](mailto:contact@irai.com), phone : +33 4 66 54 91 30, fax : +33 4 66 54 91 33,

IRAI - 17, avenue du 19 mars 1962 - BP14 - 30110 LA GRAND COMBE - FRANCE

\* trade marks by their respective manufacturers